



Installation and Operation Manual

AT-FG99

I. Product Overview

The AT-FG99 gas alarm controller, independently is a functional and user-friendly controller designed for flammable or toxic gas detection. It can be connected with gas detectors to form an industrial gas alarm system.

Using an industrial bus and RS485 digital signal transmission, the controller offers strong anti-interference capability and long transmission distance. Equipped with a high-performance processor, it completes communication and alarm response within 2 seconds. The controller supports up to 99 detectors, each configurable with two alarm values and one alarm output. It also stores up to 1050 records, including detector alarms, communication failures, and detector faults.

II. Technical Parameters

Parameter	Description
Detection Object	Flammable / Toxic / Oxygen Gas

Parameter	Description
Detection Range	0–100% LEL / 0–N% vol / 0–N μmol/mol (depending on gas sensor)
Basic Error	< ±5% F.S
Display Type	LCD Panel
Display Content	Gas Type + Measured Value + Recorded Value + Fault Signal
Alarm Type	Sound & Light Alarm
Alarm Volume	≥80 dB
Alarm Value	High/Low Alarm Settings
Communication Signal	RS485
Alarm Output	4 sets of passive normally open/closed contacts, 250V/AC 5A
Power Supply	AC220V, 50Hz
Installation	Wall-mounted
Operating Temperature	-20°C to 50°C
Operating Humidity	≤95% R.H
Operation Mode	Continuous 24/7 operation

III. Product Details

3.1 Dimensions and Appearance (Figure 3.1-1)

(Figure 3.1-1)



3.2 Control Panel (Figure 3.2-1)

(Figure 3.2-1)



[Fault] Indicates detector or communication failure.

[Linkage] Activated by an alarm trigger.

[High Alarm / Low Alarm] Indicates high or low alarm status from the detector.

[Comm 1] Shows communication status between the controller and detectors.

[Comm 2] Shows communication status between the controller and the host computer.

[Output] Indicates relay output status.

[Settings] Password-protected; used to enter settings (not for modification).

[Record]: Queries alarm records.

[Browse]: Views detector concentration readings.

[Mute]: Silences the buzzer.

[Navigation Buttons]: Confirm/return, set or adjust parameters.

IV. Basic Operation

4.1 Startup

After connecting all cables, the main power, and external devices, switch on the power (located on the right side of the chassis).

The display will show the company name, contact information, and time. Verify the time and adjust it if necessary.

The controller will then enter normal monitoring mode.

4.2 Detector Monitoring

Upon startup, the controller automatically reads data from the detectors. This process is uninterrupted by button operations.

When the gas concentration exceeds the set value, the controller triggers sound and light alarms.

Press the **[Mute]** key to silence the audible alarm. Long-press **[Mute]** to clear the alarm and disengage the linked relay.



When the gas concentration drops below the set value, the audible alarm stops automatically, but the visual alarm indicator continues flashing. The relay will not reset automatically; for safety, it must be manually disengaged.

4.3 Parameter Settings

From the home screen, press **[Settings]** and enter the password **1111**.

Caution: Do not modify internal parameters arbitrarily. Please operate under the guidance of the manufacturer's technicians.

4.3.1 Time Setting

Correct the system time in case of significant deviation after long-term operation.

4.3.2 Detector Settings

Configure parameters for each detector, including: gas type, range, high/low alarm concentrations, linkage outputs, or enabling/disabling the detector. The controller will restart automatically after changes are saved.

4.3.3 System Setting

Sets the total number of detectors, display update interval, and screen contrast.

IV. Basic Operation (Continued)

4.3.4 Output Control

Use the navigation buttons to configure the four alarm outputs. Available output modes are:

Maintained (Normal Open/Closed): After an alarm, the relay remains activated and must be manually reset.

Application: Fans, standard solenoid valves, linkage to fire protection systems, remote alarms.

Pulse: After an alarm, the relay activates for 3 seconds and then resets automatically.

Application: Emergency gas shut-off solenoid valves.

4.3.5 System Settings

Configure the controller's address and modify its operational status.

4.4 Browsing

On the main screen, press the **[Browse]** button. The controller will cycle through detector concentration readings. Toggle between two browse modes by pressing **[Browse]** again:

Display concentrations for up to 16 detectors on one screen.

Display detailed data for a single detector.

During Browsing:

Press the **Up** button to lock the current page (data continues to refresh but does not scroll).



Press the **Left/Right** buttons to switch pages.

Press the **Back** button to exit browsing.

4.5 Record Query

On the main screen, press the **[Record]** button to view the latest alarm log. Recorded events include

System startup

Communication failure (E1) and recovery (N1)

Detector failure (E2) and recovery (N2)

Detector High (H) and Low (L) alarms

Press the **Left/Right** buttons to navigate entries. Press **Back** to return to the main screen.

4.6 Mute

On the main or browsing screen, press the **[Mute]** button to silence the audible alarm.

Long-press **[Mute]** for 3 seconds to deactivate the alarm output.

V. Installation

5.1 Controller-to-Detector Connection (Figure 5.1-1)

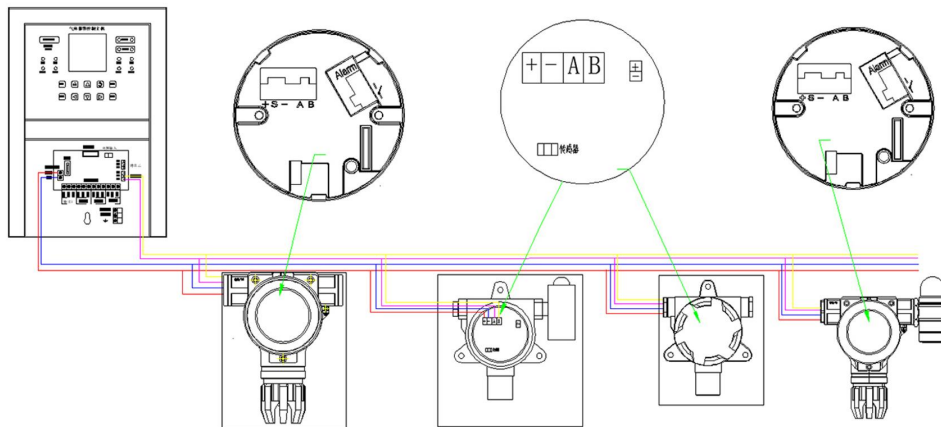

(Figure 5.1-1)

Wiring Specifications:

Signal Cable: RVVSP 2×1.0 mm²

Power Cable: RVV 2×1.0 mm²

Shielding: Single-end grounding

Connection Guide:

Connect the detector's power terminals (+ -) to the controller's **+24V** and **GND**.

Connect the detector's communication lines (**A**, **B**) to the controller's communication terminals (**A-1**, **B-1**).

Connect the cable shield to the controller's communication **GND**.

Note: The controller's 24V power output is protected by a 10A fuse. If there is no 24V output, please check the fuse.

5.2 Controller Wiring Diagram (Figure 5.2-1)

(Figure 5.2-1)

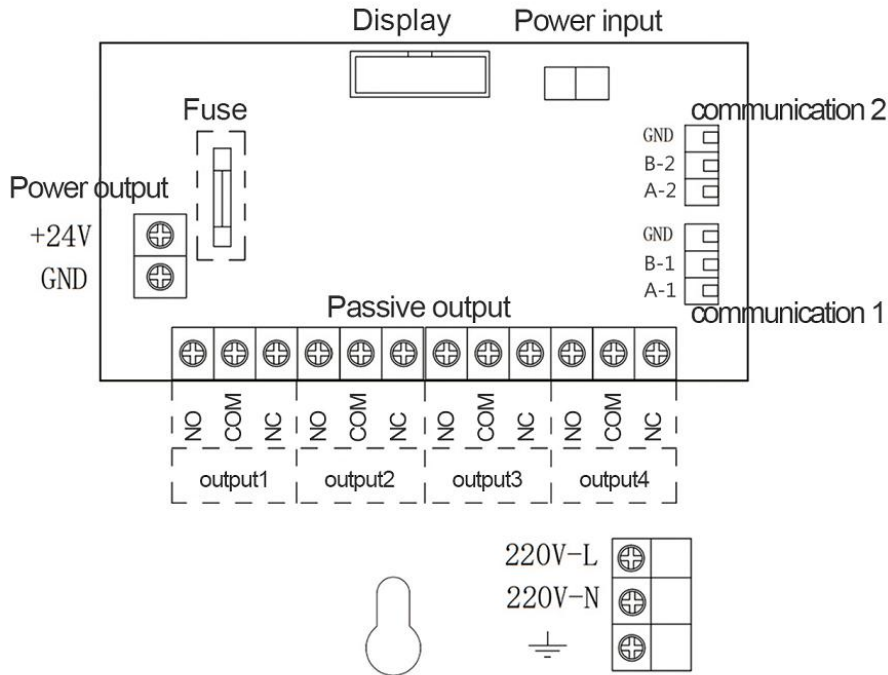

V. Installation (Continued)

5.3 Controller Linkage

The controller can directly control devices with a current $\leq 5A$ and power $\leq 500W$. For devices exceeding these ratings, an AC contactor or our optional linkage control box must be used.

① Linkage with 220V Fan (Figure 5.3-1)

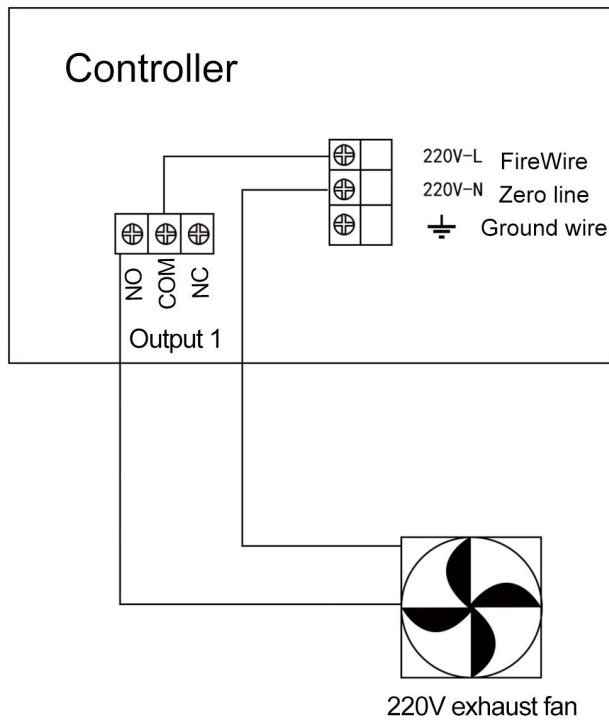

(Figure 5.3-1)

② Linkage with 220V Normally Open Solenoid Valve (Figure 5.3-2)

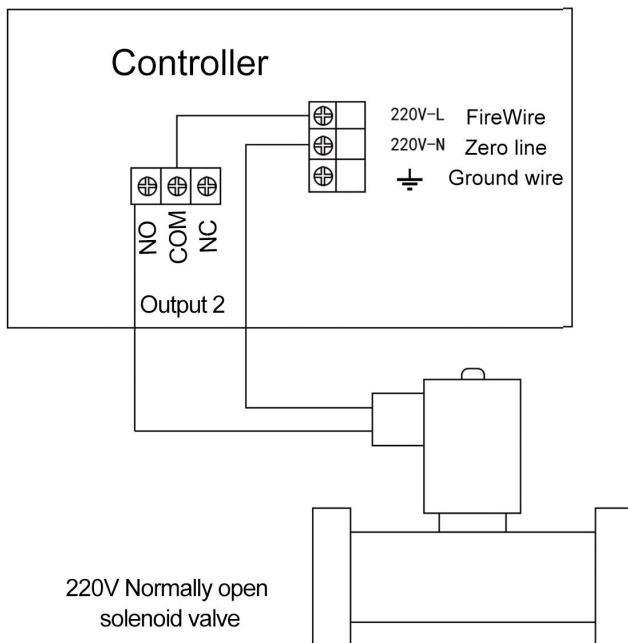



Important Note for Emergency Shut-off Valves

Gas emergency shut-off valves must **not** be powered continuously. Ensure compatibility before connection.

When connecting a combustible gas detector, the emergency shut-off valve **must be connected to Output 2**.

This channel provides a 3-second pulse output. Upon alarm, the solenoid valve is energized for 3 seconds, after which power is automatically cut off. The gas emergency shut-off valve must be manually reopened after the leak has been resolved.

VI. Controller Maintenance

The controller must be powered by a dedicated power supply and must not share a circuit with other equipment.

Do not disassemble the unit.

Do not expose the detector to water, oil, or corrosive gases.

The controller should be installed in a control room or instrument panel. Operation by unauthorized personnel is prohibited.

Do not modify menu settings without authorization. For any configuration changes, please contact our company and proceed under the guidance of a technician. The user assumes full responsibility for any consequences of unauthorized operation.

VII. Warranty & Service

The product is covered under standard warranty services.

The free warranty period is one year from the date of purchase. Please adhere to the user manual.

For any malfunctions, please contact the manufacturer.

The warranty is void under the following circumstances:

Damage or malfunction resulting from failure to follow the instructions in this manual.

Failure or damage caused by unauthorized disassembly, modification, or repair.

Lifetime maintenance is provided for all sold equipment. Repairs outside the warranty period will incur service charges.

VIII. Disclaimer

This manual describes the product's usage and technical parameters. The company reserves the right to revise this manual without prior notice.

The product's actual appearance may differ slightly from the images in this manual due to printing variations. Please refer to the physical product.

The content is for reference only and does not constitute a formal commitment.

All rights reserved. No part of this manual may be extracted, reproduced, or distributed in any form without the company's prior written permission.